

Electro-Voice®

a MARK IV company

WCB-2 Wall Mounting Bracket Kit

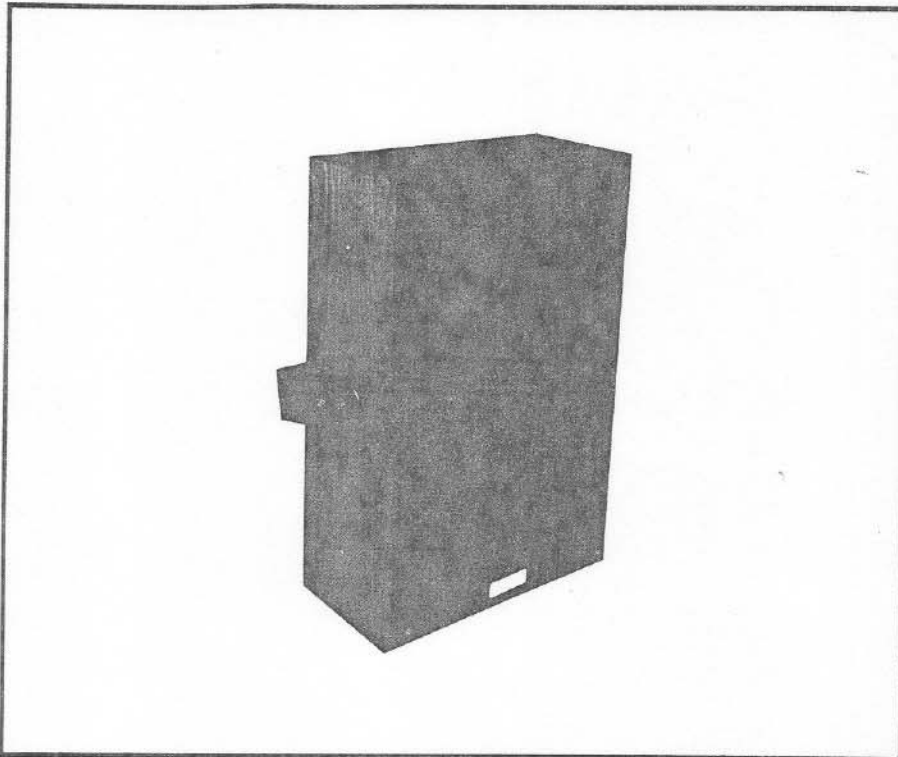

SPECIFICATIONS

Mounting Bracket Kit:

Contains two bracket assemblies designed to fit the FR12-2B

Wall Mounting Holes:

Three 0.28-inch diameter clearance holes, evenly spaced 6.5 inches apart

Enclosure Positioning Feature:

The radial slot allows three position settings: 0°, 15°, and 20°

Material:

Cold rolled steel

Finish:

Black Paint

Net Weight:

1.6 kg (3 lb 10 oz)

Shipping Weight:

3.6 kg (8 lb)

DESCRIPTION

The WCB-2 wall mounting bracket kit is designed to permanently mount the Electro-Voice model FR12-2B speaker system.

The WCB-2 allows the cabinet to rotate about its mounting center permitting angular adjustment after attachment to the wall. Locking screws are included to secure the system in its final position. The WCB-2 allows the FR12-2B to be mounted from 0° to 20°, to achieve desired sound coverage.

The WCB-2 supports the FR12-2B with four 1/4-20 hex-head screws which fasten the bracket to threaded inserts in the cabinet. A set of mounting screws and washers are included with the WCB-2 kit.

The radial slot provides quick adjustments, allowing any one of the three standard positions (0°, 15° and 20°) or any setting between. Aligning the back screw with the

center indentation sets the bracket at 15°, the bottom setting is 0°, and the maximum angle is 20°.

MOUNTING

The WCB-2 is designed to mount on the center set of inserts on the long dimension of the FR12-2B enclosure. To access the inserts on the FR12-2B, remove the cap plugs concealing the inserts.

1. Mount the WCB-2 bracket to the wall.
2. Set the FR12-2B on the bracket using the shoulder washers and screws provided into

CAUTION:

Due to the weight of the FR12-2B enclosure, it is imperative that the WCB-2 bracket be properly secured to the wall. The choice of fastener (not provided with bracket kit) will be determined by the material and construction of the wall.

the front slotted screw holes. Place the shoulder washers between the bracket and the speaker.

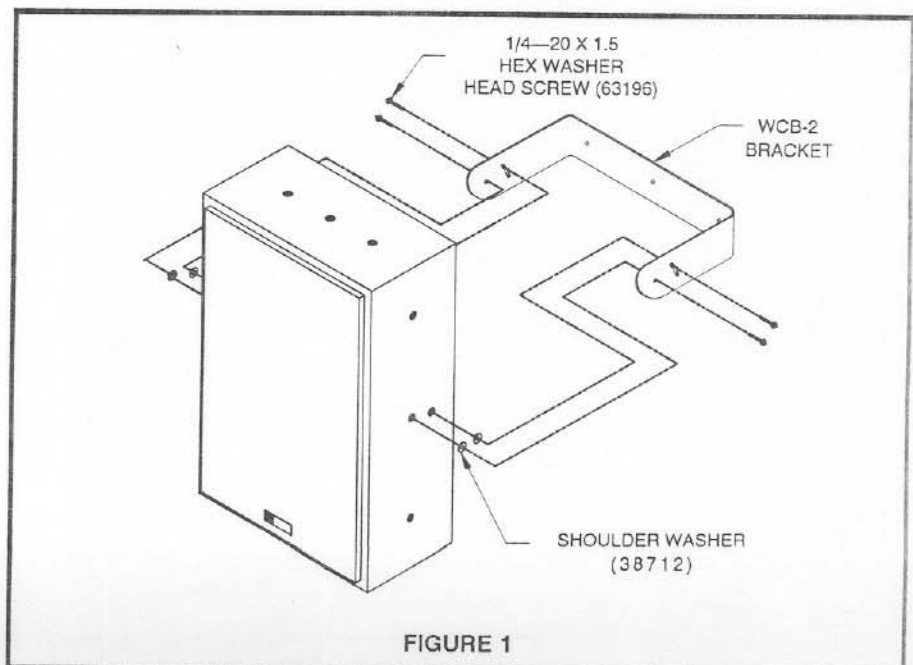

FIGURE 1

3. Insert the rear screws into the radial slot in a similar manner.
4. Rotate the speaker to the desired angle then tighten the rear screws. Note: sliding the screws to the rear of the center slot will set the speaker at 15° to the floor.
5. Tighten the remaining screws.

Figure 1 illustrates how the FR12-2B is positioned on the WCB-2 bracket using the center inserts. Included for reference are the EV part numbers for the screws and shoulder washers.

WARRANTY (Limited)

Electro-Voice products are guaranteed against malfunction due to defects in materials or workmanship for a specified period, as noted in the individual product-line statement(s) below, or in the individual product data sheet or owner's manual, beginning with the date of original purchase. If such malfunction occurs during the specified period, the product will be repaired or replaced (at our option) without charge. The product will be returned to the customer

prepaid. **Exclusions and Limitations:** The Limited Warranty does not apply to: (a) exterior finish or appearance; (b) certain specific items described in the individual product-line statement(s) below, or in the individual product data sheet or owner's manual; (c) malfunction resulting from use or operation of the product other than as specified in the product data sheet or owner's manual; (d) malfunction resulting from misuse or abuse of the product; or (e) malfunction occurring at any time after repairs have been made to the product by anyone other than Electro-Voice or any of its authorized service representatives. **Obtaining Warranty Service:** To obtain warranty service, a customer must deliver the product, prepaid, to Electro-Voice or any of its authorized service representatives together with proof of purchase of the product in the form of a bill of sale or receipted invoice. A list of authorized service representatives is available from Electro-Voice at 600 Cecil Street, Buchanan, MI 49107 (616/695-6831) and/or Electro-Voice West, at 8234 Doe Avenue, Visalia, CA 93291 (209/651-7777). **Incidental and**

Consequential Damages Excluded: Product repair or replacement and return to the customer are the only remedies provided to the customer. Electro-Voice shall not be liable for any incidental or consequential damages including, without limitation, injury to persons or property or loss of use. Some states do not allow the exclusion or limitation of incidental or consequential damages so the above limitation or exclusion may not apply to you. **Other Rights:** This warranty gives you specific legal rights, and you may also have other rights which vary from state to state.

Electro-Voice Accessories are guaranteed against malfunction due to defects in materials or workmanship for a period of one (1) year from the date of original purchase. Additional details are included in the Uniform Limited Warranty statement.

Service and repair address for this product: Electro-Voice, Inc., 600 Cecil Street, Buchanan, Michigan 49107.

Specifications subject to change without notice.



ELECTRO-VOICE, INC., 600 Cecil Street, Buchanan, Michigan 49107

MANUFACTURING PLANTS AT ■ BUCHANAN, MI ■ NEWPORT, TN ■ SEVIERVILLE, TN ■ OKLAHOMA CITY, OK ■ GANANOQUE, ONT.
 ©Electro-Voice, Inc. 1992 ■ Litho in U.S.A. Part Number 531968 — 244

a MARK IV company